

## 2.5 Contamination Protection

### End Seal

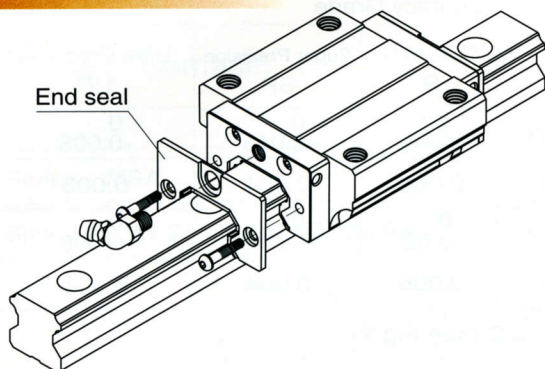

### Bottom Seal

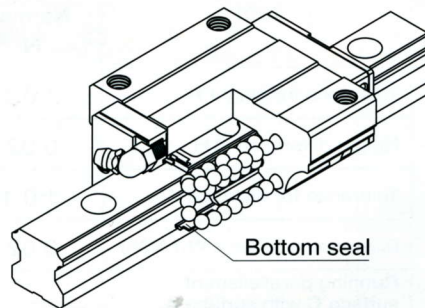

### Double End Seal

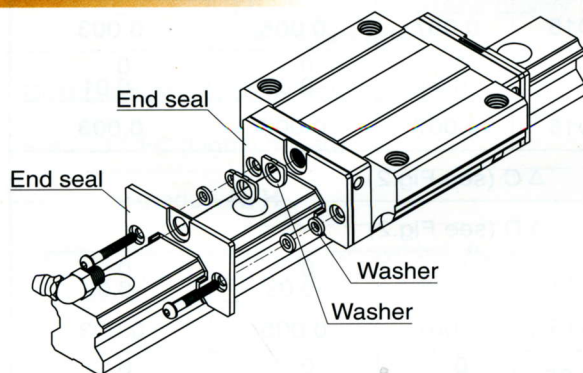

### Metallic Scraper

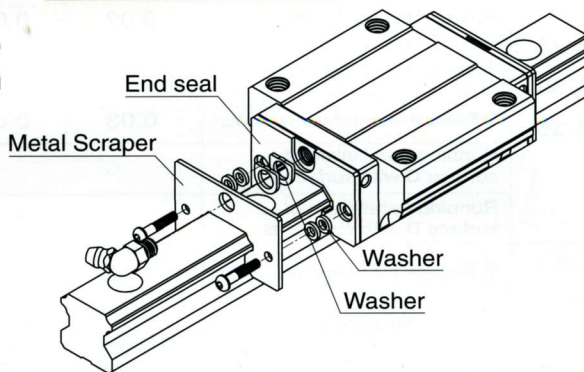

### Code of Contamination Protection

Code	Contamination Protection
No symbol	Scraper (both ends)
UU	Bidirectional end seal (both ends)
SS	Bidirectional end seal + Bottom seal
ZZ	SS + Scraper
DD	Double bidirectional end seal + Bottom seal
KK	DD + Scraper
LL	Low frictional end seal
RR	LL + Bottom seal

### Code of Carriage

Series : MSA

Size : 15, 20, 25, 30, 35, 45, 55, 65

Carriage type : (1) Heavy load  
 A : Flange type, mounting from top  
 E : Flange type, mounting either from top or bottom  
 S : Square type

(2) Ultra heavy load  
 LA : Flange type, mounting from top  
 LE : Flange type, mounting either from top or bottom  
 LS : Square type

Dust protection option of carriage : No symbol, UU, SS, ZZ, DD, KK, LL, RR  
 (refer to chapter 15.1 Dust Proof)

Preload : FC (Light preload), F0 (Medium preload)

Accuracy grade : N, H, P

### Types of seal to the increment to the carriage overall length

Unit : mm

Model No.	No symbol	UU	SS	LL	RR	ZZ	DD	KK
MSA 15	1	-	-	-	-	6	5	11
MSA 20	1.4	-	-	-	-	7	5.6	12.6
MSA 25	1.4	-	-	-	-	7	5.6	12.6
MSA 30	1.4	-	-	-	-	7	5.6	12.6
MSA 35	0.6	-	-	-	-	7.8	7.2	15
MSA 45	0.6	-	-	-	-	7.8	7.2	15
MSA 55	0.6	-	-	-	-	7.8	7.2	15
MSA 65	0.6	-	-	-	-	7.8	7.2	15